

**Submittal Data:24RLXFZ
Inverter Driven Heat Pump**

24,000 BTU Multi Zone System

Job Name: _____

Date: _____

Location: _____

Approval: _____

Engineer: _____

Construction: _____

Submitted to: _____

Unit #: _____

Submitted by: _____

Drawing #: _____

Reference: _____

General Features

- Blue fin heat exchanger
- Extra long piping allotment
- Wired and wireless remote controllers
- Automatic airflow adjustment
- Economy operation
- 5- Years Parts, 7-Years Compressor Warranty (See Warranty Statement for details)
- 24 hr. Timer
- Low operating temperature

Model Information

Condenser..... AOU24RLXFZ
 Evaporator*1..... (ASU) / (ARU) / (AGU) / (AUU) 7,9,12RLF(1)
 Connectable indoor units..... 2 - 3
 Total capacity range..... 14,000 – 27,000 Btu/h

Electrical..... 208/230V AC 1ph-60Hz
 Available Voltage Range..... 208/230 +/- 10%
 Minimum Circuit Ampacity..... 17 A
 Max Fuse Size..... 20 A
 Max Starting Current..... 9.0 A

Input Power

Cooling..... (non-duct) 1.76 kW / (ducted) 2.08 kW / (mix) 1.90 kW
 Heating..... (non-duct) 1.73 kW / (ducted) 2.05 kW / (mix) 1.88 kW

Current

Cooling..... (non-duct) 7.7 A / (ducted) 9.1 A / (mix) 8.4 A
 Heating..... (non-duct) 7.6 A / (ducted) 9.0 A / (mix) 8.3 A

Capacity

Nominal Cooling..... 22,000 Btu/h
 Min-Max Cooling..... 6,100 – 27,000 Btu/h
 Nominal Heating..... 24,000 Btu/h
 Min-Max Heating..... 6,800 – 29,800 Btu/h

Compressor

..... Rotary (inv x1)
 Motor Output..... 1,100 W
 Refrigerant..... R410a
 Charge..... 4 lbs. 14 oz
 Oil..... POE

Fan Motor

(Condenser) Type: DC Propeller x1
 (Condenser) Motor Output..... 100 W
 (Evaporator) Type: DC..... (wall-mount) Cross flow
 (compact cassette) Turbo
 (ducted) Sirocco
 (floor) Cross flow x2

(Evaporator) Motor Output..... (wall) 30W-42W (compact cassette) 54W (ducted) 80-81W
 (floor) 16W

Heat Exchanger

Dimensions (condenser)
 (H x W x D) in. (mm)..... 26-7/16 x 35-7/16 x 1-7/16 (672x900x36.38)
 Fin Pitch..... 18 FPI
 Rows x Stages..... 2 x 32
 Pipe Type (Material)..... Copper
 Fin Type (Material)..... Aluminum (Blue fin)



Operation Temperature Range

Cooling..... 14°F - 115°F (-10°C - 46°C)
 Heating..... 5°F - 75°F (-15°C - 24°C)

Efficiency

SEER*2..... (wall-mount) 18 (duct) 15.50 (mix) 16.75
 EER (cooling).. (wall-mount) 12.50 Btu/W (duct) 10.60 Btu/W (mix) 11.55 Btu/W
 COP (heating)..... (wall-mount) 4.04 W/W (duct) 3.42 W/W (mix) 3.74 W/W
 HSPF (heating)..... (wall-mount) 9.50 (duct) 9.00 (mix) 9.25

Enclosure (Condenser)

Material..... Painted galvanized steel
 Color..... Beige (10 YR 7.5/1.0 NN)

Sound Pressure Level

Condenser..... 52 dB(A)

Dimensions

H x W x D
 Condenser
 Net in. (mm)..... 27-9/16 x 35-7/16 x 13 (700x900x330)
 Gross in. (mm)..... 32-7/8 x 41-5/16 x 17-1/2 (835x1050x445)

Connection Pipe

Liquid..... 1/4" x3
 Gas..... 3/8" x2 + 1/2" x1
 Method (Liquid/Gas)..... Brazing
 Max Length (Pre-charge)..... 164ft. (50m) / (98 ft. {30m})
 Max Height Difference..... 49 ft. (15m)

Weight

Condenser..... 124 lbs. (56 kg)
 Evaporators..... (wall-mount) 19 lbs. - 31 lbs.
 (compact cassette) 33 lbs.
 (ducted) 37 lbs. - 49 lbs.
 (floor) 31 lbs.

Accessories

Wired Remote Controller..... UTY-RVNUM
 Wired Remote Controller..... UTY-RNNUM
 Simple Remote Controller..... UTY-RSNUM

*1 Reference brochure for approved combinations. *2 Test conditions are based on AHRI 210/240.
 Note: Specifications are based on the following conditions. Cooling: Indoor temperature of 80°F (26.7°C) DB/67°F (19.44°C) WB, and outdoor temperature of 95°F (35°C) DB/75°F (23.9°C) WB. Heating: Indoor temperature of 70°F (21.11°C) DB/59°F (15.°C) WB, and outdoor temperature of 47°F (8.33°C) DB/43°F (6.11°C) WB. Pipe length: 24ft. 7in. (7.5m). Height difference: (ft. (0m) (Outdoor unit - indoor unit))



Dimensions:24RLXFZ

[Unit: in. (mm)]

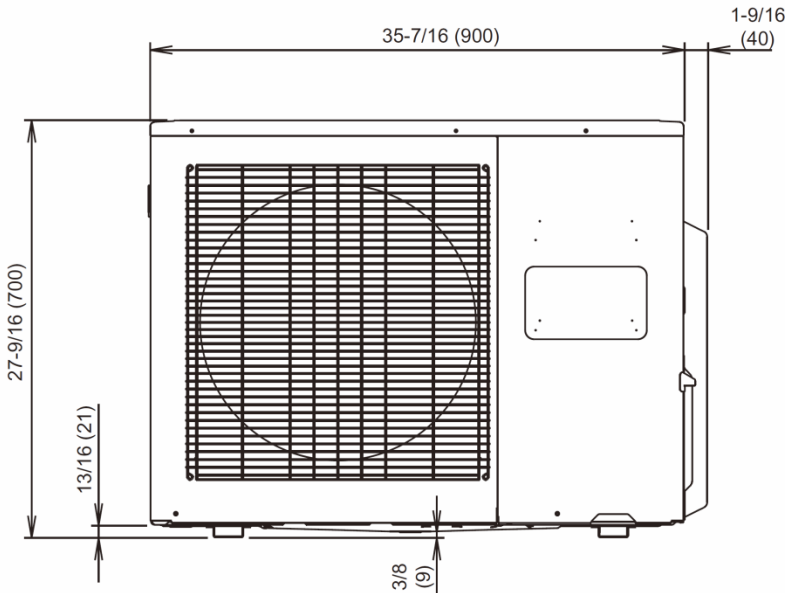

Front view

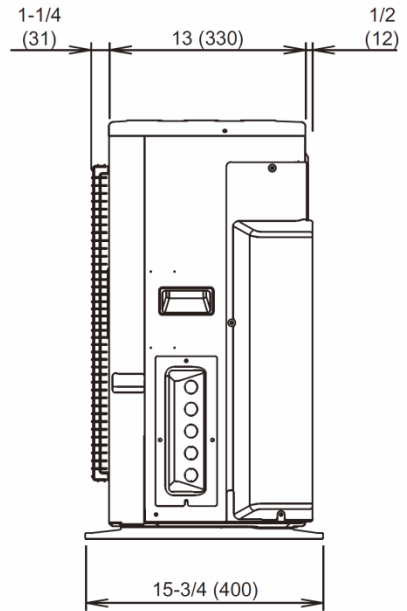

Side view

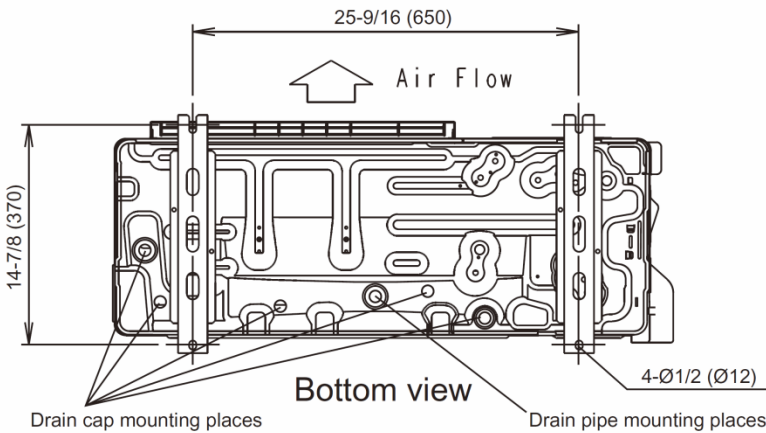

Bottom view

